

NOTE:  
 1. ENCLOSED DIMENSIONS DENOTES INSPECTION DIMENSION  
 2. PARTS SHOULD BE FREE FROM OIL, DIRT & OTHER FOREIGN CONTAMINATION  
 3. ALL EDGES HAVE NO BURRS OR PROTRUSION AFTER SINGULATION FROM THE PANEL  
 4. UL94V-0 WITHOUT USING HALOGENS, ANTIMONY OR PHOSPHOROUS COMPOUND  
 5. MATERIAL: CCL-HL832NX TYPE A OR GHPL-830NX TYPE A

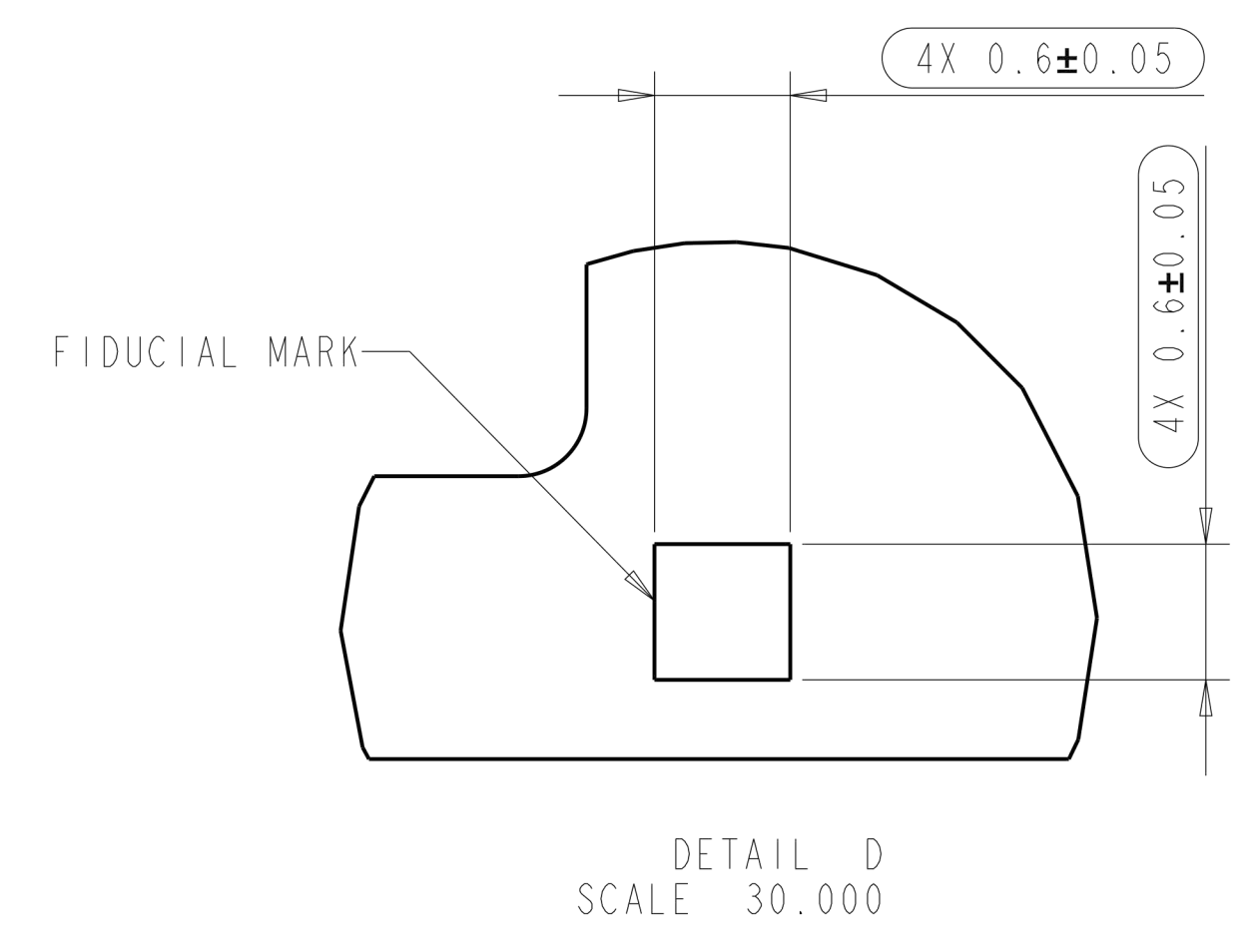

手机微信同号: 18824309157

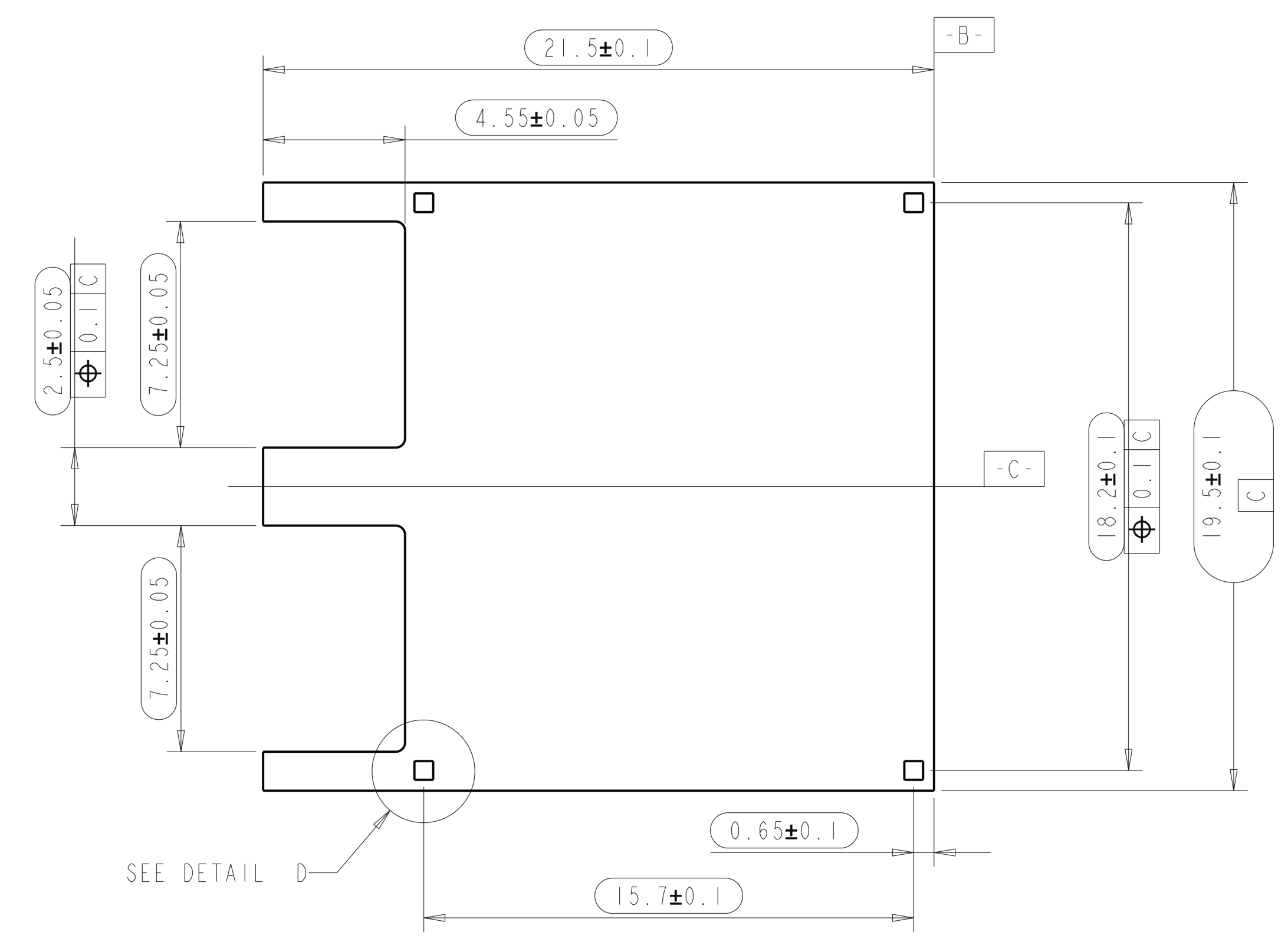
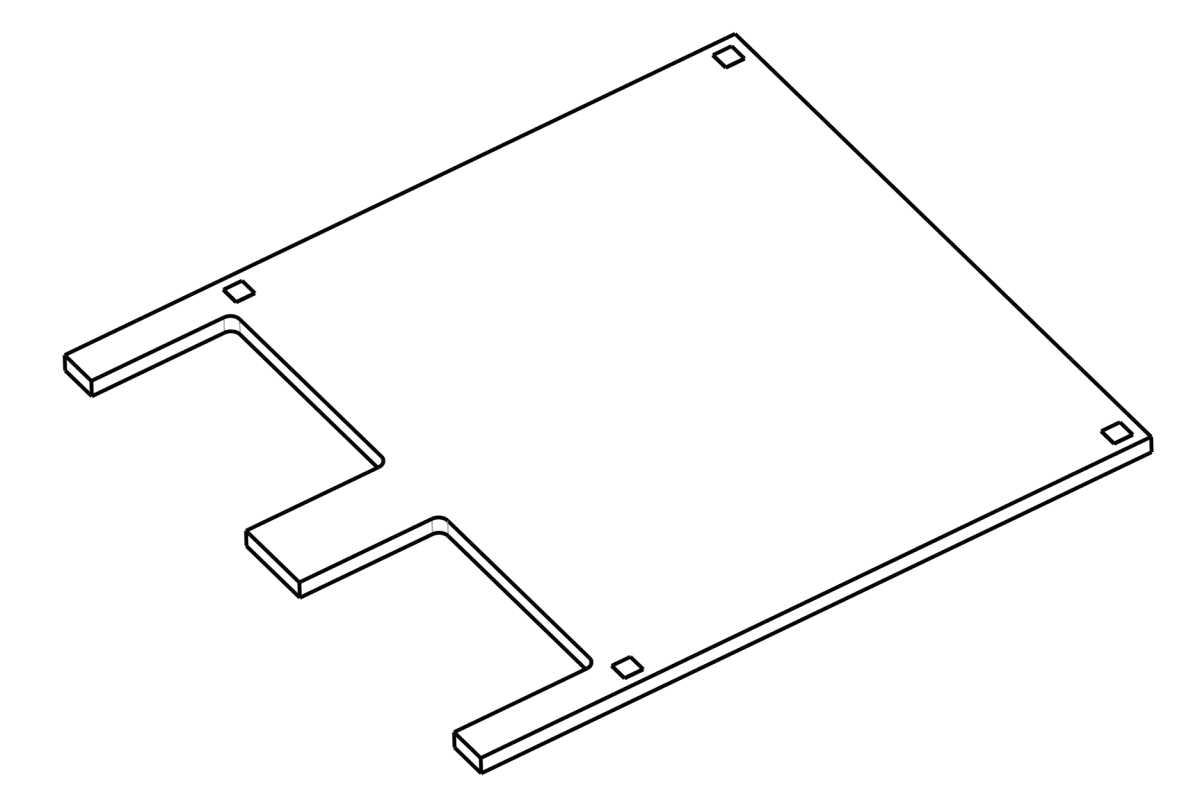
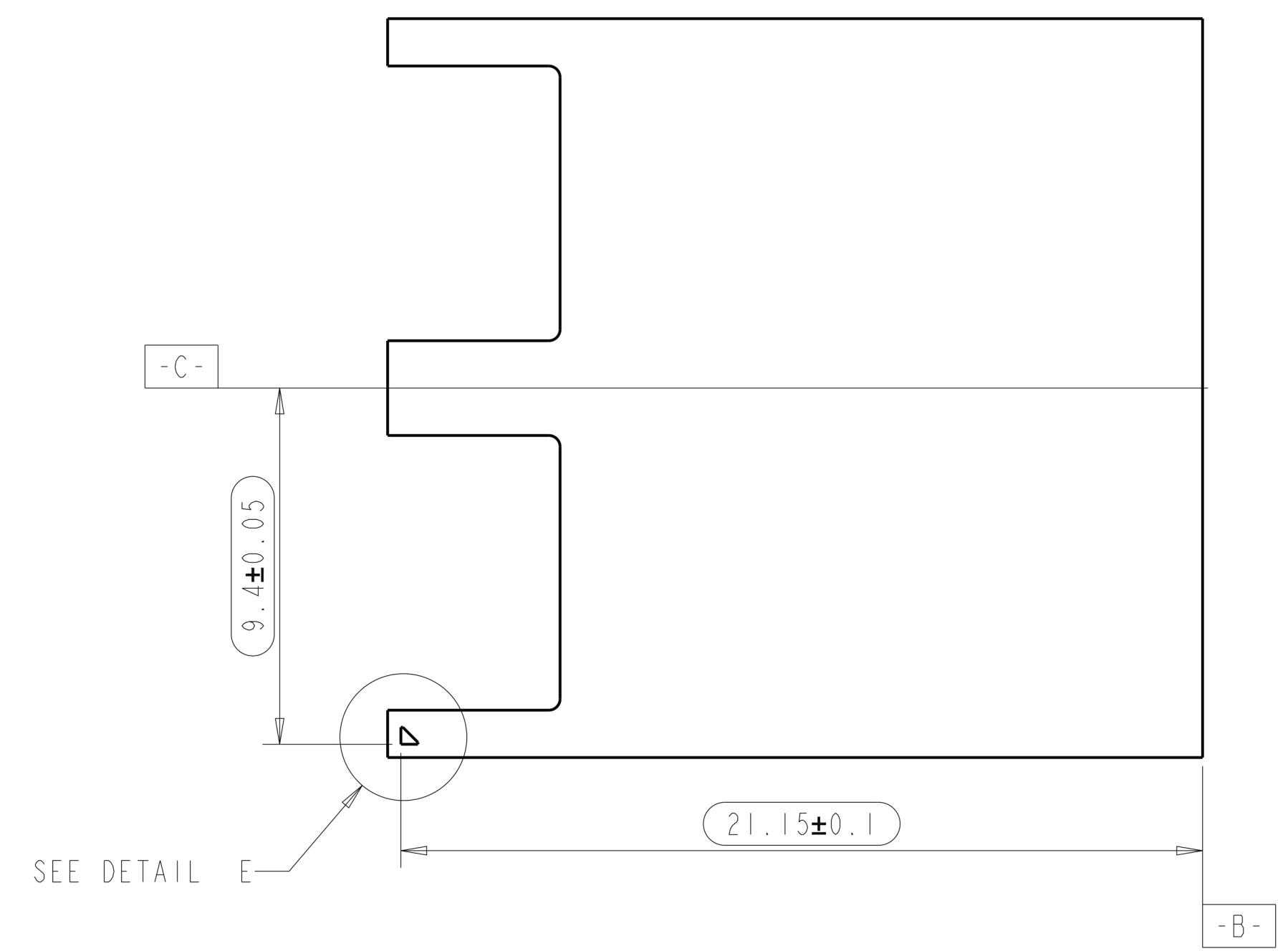
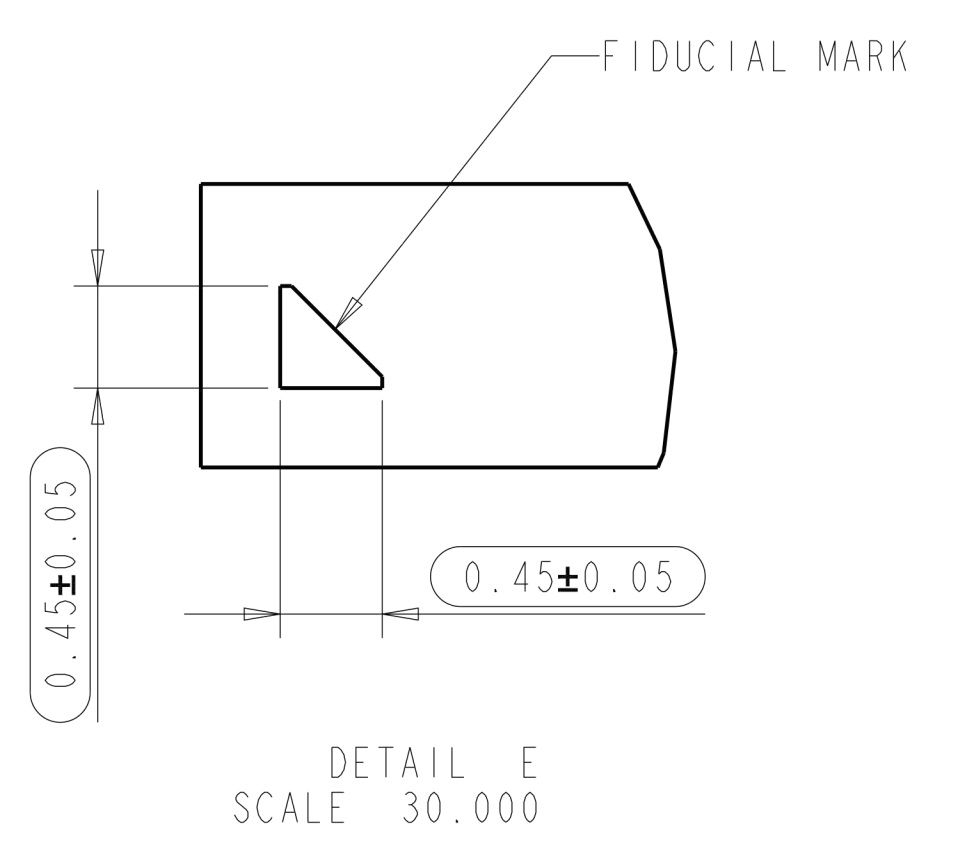

CLOUD LIGHT TECHNOLOGY LTD UNLESS OTHERWISE SPECIFIED ALL DIMENSIONS ARE IN MM	DRAWN: MPB CHECK: ENGR:	NAME: ALDAN-G BETA SUBSTRATE
	TOLERANCES: .XX±0.15 .XX±0.10 .XXX±0.075	ANGULAR: ±1.0°
FINISHED:	SEE NOTE 5	SCALE: A00 DWG. NO.: XXXX-XX-XXXX UNITS: MM
THIRD ANGLE PROJECTION		REV P01 SHEET 1 OF 2